

# BVE-LW 1500 TO 2000

*Single heat exchanger - Large area for HP*

---



The BVE-LW series tanks comes with an enamelled tank and a large heat exchanger surface. They are suitable for heat pump applications. These tanks are to be placed on the ground.



# Description

- Enamelled steel sanitary hot water storage tank\*, equipped with one heat exchanger with a large area.
- Tank enamelling inside treatment according to DIN 4753-3 and UNI 10025. Protection by magnesium anode.
- Polyester fiber insulation 100 mm thick, PVC cover finish, removable.
- Optional electric back-up on 1 1/2" connection above the heat exchanger.
- External casing classified as standard M1 fire.
- 3 years warranty, electric part 2 years warranty.

\* Sanitary water in compliance with French sanitary regulations particularly DTU 60.1

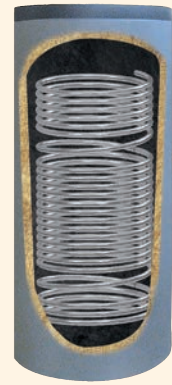

## BVE-LW 1500 and 2000 liters

	Model	1500 L	2000 L
<b>Reference</b>		<b>BVE1500LW</b>	<b>BVE2000LW</b>
Total capacity (liters)		1300	1900
Weight empty (kg)		370	573
Polyester fiber insulation (mm)			100
Heat exchanger surface (m <sup>2</sup> )		8.0	13.0
Heat exchanger volume (L)		68.5	102.0
Heat exchanger power (kW) at *60-80°C		225	340
Heating water production at 60-80°C (m <sup>3</sup> /h)		9.7	14.6
Domestic hot water production at 10-45°C (m <sup>3</sup> /h)		5.5	8.4
Pressure loss at 60-80°C (mbar)		620	2020
Energy efficiency class			C
Maximum working-temperature (°C)			95
Max tank operating pressure (bar)			8
Max working heat exchanger pressure (bar)			10

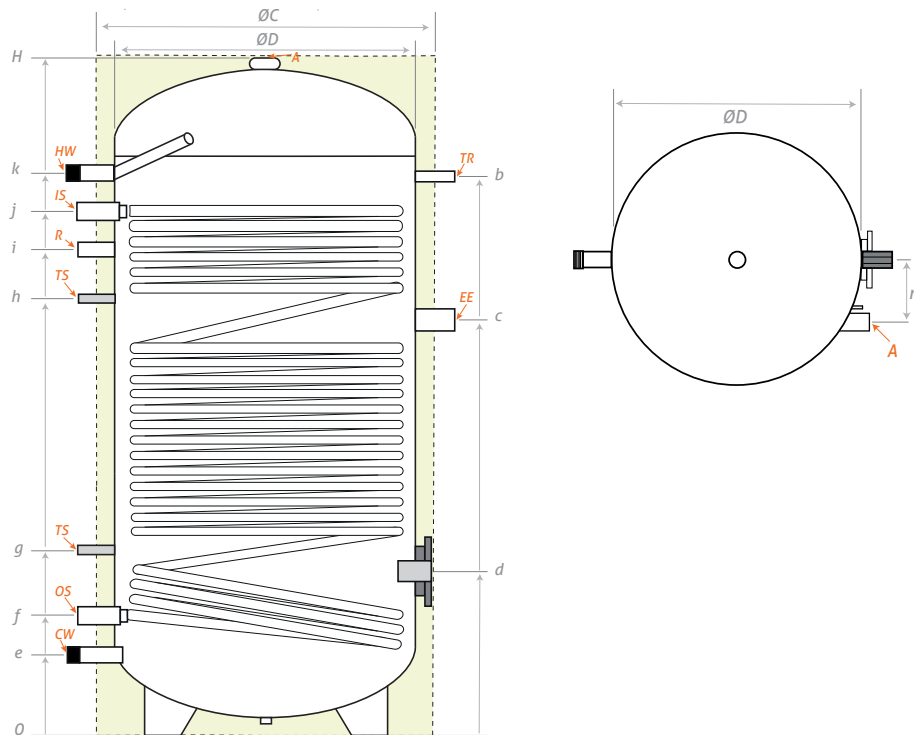

	Model
<b>Outlet/Inlet tube</b>	<b>1500-2000</b>
<b>CW</b> Cold Water inlet	1" 1/2
<b>A</b> Anode	1" 1/2
<b>HW</b> Hot Water outlet	1" 1/2
<b>IS</b> Heat exchanger inlet	1" 1/4
<b>OS</b> Heat exchanger outlet	1" 1/4
<b>TS</b> Temperature probes	1/2"
<b>EE</b> Electric element	1" 1/2
<b>R</b> Recirculation	1"
<b>TR</b> Temperature probes	1/2"

**Storage tank 3 years warranty**

## Certifications

Tank enamelling inside treatment according to DIN 4753-3 and UNI 10025  
Made in European Union



Model	ØC	ØD	H	b	c	d	e	f	g	h	i	j	k	n
1500	1200	1000	2085	1720	1210	550	310	425	615	1285	1470	1625	1770	230
2000	1300	1100	2470	2110	1570	550	260	380	580	1620	1815	2020	2140	230

Dimensions (mm)

**SYRIUS SOLAR INDUSTRY**  
15 rue du Perpignan - ZAC Descartes  
34880 Lavérune - France

+33 (0) 4 67 82 00 18  
contact@syrius-solar.fr

SAS with capital of € 156 800 - RCS Montpellier 794 797 753 00041

[www.syrius-solar.com](http://www.syrius-solar.com)

