

# BVE-WM32 80 TO 150 BHE-WM32 120



The BVE and BHE - WM series tanks are specially designed for indirect circuit solar systems with heat exchanger.

The tank and the heat exchanger are made of enamelled steel. The storage tank is equipped on the side of collector departure outlet and collector return inlet, separately from the cold water inlet and domestic hot water outlet.

Mounting is done vertically on a load-bearing wall for BVE-WM and horizontally for BHE-WM.



# Description

- Sanitary hot water storage tank \* in enamelled steel, with one heat exchanger.
- Tank enamelling inside treatment according to DIN 4753-3 and UNI 10025. Protection by magnesium anode.
- Rigid PU insulation injected, white pre-painted metal finish.
- Supplied with electric back-up, ON / OFF switch and two-color indicator light:  
Red light: heating  
Blue light: Ready-to-use DHW
- 5 years warranty, electrical part 2 years warranty

\* Sanitary water meeting the French standard according to decree N° 89-3 of 03/01/89

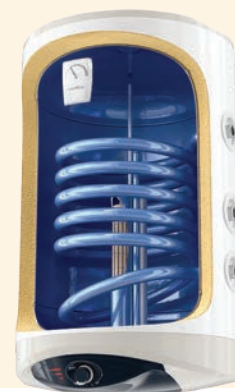

## BVE-WM32 80, 100 and 150 liters BHE-WM32 120 liters

Model	80 L	100 L	150 L	120 L
Reference	BVE0080WM32	BVE0100WM32	BVE0150WM32	BHE0120WM32
Position	Vertical	Vertical	Vertical	Horizontal
Total capacity (liters)	79	96	138	118
Heat exchanger surface (m <sup>2</sup> )	0.45	0.7	0.8	0.28
Heat exchanger volume (L)	2.1	3.2	3.9	1.2
Heat exchanger power (kW) at *60-80°C	13.8	18.5	20.9	5.7
Electric back-up with switch: steatite	2.4 kW-230V		2 kW-230V	
Rigid PU insulation (mm)	32			
Continuous flow rate of DHW at ΔT 35° at 60-80°C (L/h)	329	433	514	139
Heating time ΔT 45K (15-60° C) 80° C (h:mm)	0:18	0:18	0:21	0:48
Energy efficiency class	B		C	
Maximum working-temperature (°C)	95			

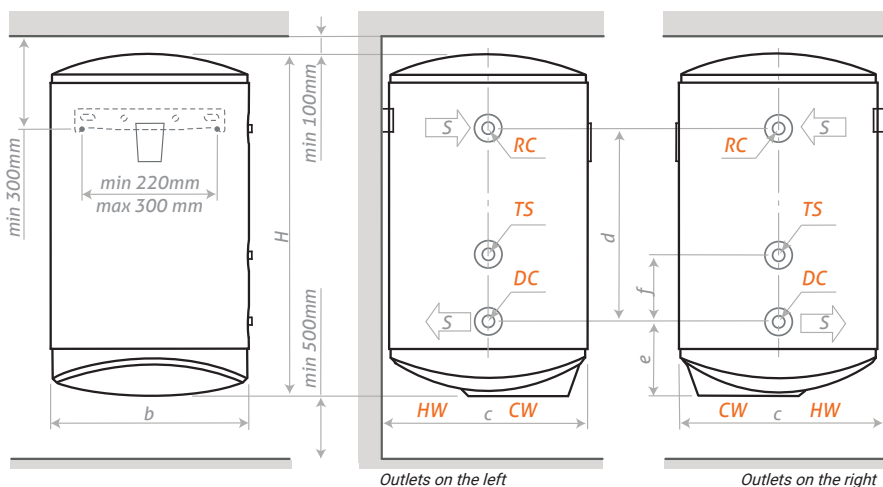

Outlet/Inlet tube	Model	80 to 150
CW	Cold Water inlet	1/2"
HW	Hot Water outlet	1/2"
RC	Collector inlet	3/4"
DC	Collector outlet	3/4"
TS	Temperature probes	1/2"

Model	∅	H	b	c	d	e	f
800	470	845	470	496	295	243	120
100	470	985	470	496	445	243	120
150	470	1315	470	496	445	243	120
120	470	1150	470	496	702	480	-

Dimensions (mm)

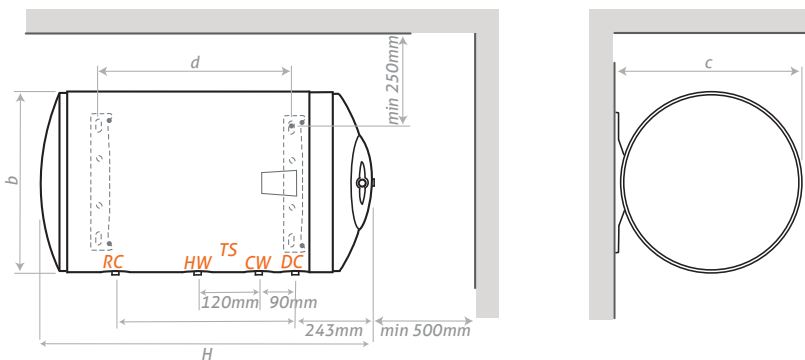

**Storage tank 5 years warranty**

## Certifications

Tank enamelling inside treatment according to DIN 4753-3 and UNI 10025  
Made in European Union



**SYRIUS SOLAR INDUSTRY**  
15 rue du Perpignan - ZAC Descartes  
34880 Lavérune - France

(+33) 4 67 82 00 18  
contact@syrius-solar.fr

SAS with capital of € 156 800 - RCS Montpellier 794 797 753 00041

[www.syrius-solar.com](http://www.syrius-solar.com)

