

# BVE-LW 800 TO 2000

*Single heat exchanger - Large area for HP*

---



The BVE-LW series tanks comes with an enamelled tank and a large heat exchanger surface. They are suitable for heat pump applications. These tanks are to be placed on the ground.



# Description

- Enamelled steel sanitary hot water storage tank\*, equipped with one heat exchanger with a large area.
- Tank enamelling inside treatment according to DIN 4753-3 and UNI 10025. Protection by magnesium anode.
- Polyester fiber insulation 100 mm thick, PVC cover finish, removable.
- Optional electric back-up on 1 1/2" connection above the heat exchanger.
- External casing classified as standard M1 fire.
- 3 years warranty, electric part 2 years warranty.

\* Sanitary water meeting the French standard according to decree N° 89-3 of 03/01/89



## BVE-LW 800, 1000, 1500 and 2000 liters

Model	800 L	1000 L	1500 L	2000 L
<b>Reference</b>	<b>BVE0800LW</b>	<b>BVE1000LW</b>	<b>BVE1500LW</b>	<b>BVE2000LW</b>
Total capacity (liters)	702	900	1300	1900
Weight empty (kg)	235	265	370	573
Polyester fiber insulation (mm)	100			
Heat exchanger surface (m <sup>2</sup> )	7.0	8.0	8.0	13.0
Heat exchanger volume (L)	60.0	68.5	68.5	102.0
Heat exchanger power (kW) at *60-80°C	189	216	225	340
Heating water production at 60-80°C (m <sup>3</sup> /h)	8.1	9.3	9.7	14.6
Domestic hot water production at 10-45°C (m <sup>3</sup> /h)	4.6	5.3	5.5	8.4
Pressure loss at 60-80°C (mbar)	354	515	620	2020
Energy efficiency class	C			
Maximum working-temperature (°C)	95			
Max tank operating pressure (bar)	10		8	
Max working heat exchanger pressure (bar)	10			

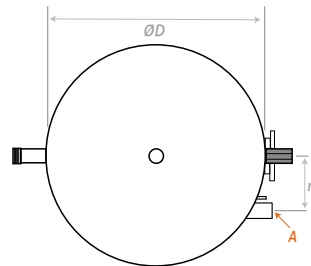
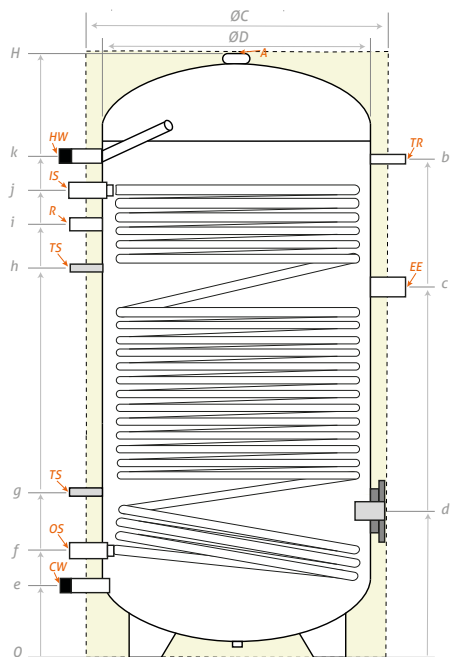

Outlet/Inlet tube	Model	
	800-1000	1500-2000
<b>CW</b> Cold Water inlet	1" 1/4	1" 1/2
<b>A</b> Anode	1" 1/2	1" 1/2
<b>HW</b> Hot Water outlet	1" 1/4	1" 1/2
<b>IS</b> Heat exchanger inlet	1" 1/4	1" 1/4
<b>OS</b> Heat exchanger outlet	1" 1/4	1" 1/4
<b>TS</b> Temperature probes	1/2"	1/2"
<b>EE</b> Electric element	1" 1/2	1" 1/2
<b>R</b> Recirculation	1"	1"
<b>TR</b> Temperature probes	1/2"	1/2"

**Storage tank 3 years warranty**

## Certifications

Tank enamelling inside treatment according to DIN 4753-3 and UNI 10025  
Made in European Union



Model	ØC	ØD	H	b	c	d	e	f	g	h	i	j	k	n
<b>800</b>	990	790	1875	1610	1120	470	240	345	565	1175	1305	1485	1620	200
<b>1000</b>	990	790	2205	1940	1435	470	240	345	515	1485	1615	1830	1940	200
<b>1500</b>	1200	1000	2085	1720	1210	550	310	425	615	1285	1470	1625	1770	230
<b>2000</b>	1300	1100	2470	2110	1570	550	260	380	580	1620	1815	2020	2140	230

Dimensions (mm)

**SYRIUS SOLAR INDUSTRY**  
15 rue du Perpignan - ZAC Descartes  
34880 Lavérune - France

+33 (0) 4 67 82 00 18  
contact@syrius-solar.fr

SAS with capital of € 156 800 - RCS Montpellier 794 797 753 00041

[www.syrius-solar.com](http://www.syrius-solar.com)

